

S12706

High sensitivity, photosensitive area with minute pixels

The S12706 is a high sensitivity CMOS linear image sensor using a photosensitive area with minute pixels. It has a long photosensitive area (effective photosensitive length: 28.672 mm) consisting of 4096 pixels, each with a pixel size of $7 \times 7 \mu\text{m}$.

Features

- Pixel size: $7 \times 7 \mu\text{m}$
- 4096 pixels
- Effective photosensitive area length: 28.672 mm
- High sensitivity: $23 \text{ V}/(\text{lx}\cdot\text{s})$
- Simultaneous charge integration for all pixels
- Variable integration time function (electronic shutter function)
- 5 V single power supply operation
- Built-in timing generator allows operation with only start and clock pulse inputs.
- Video data rate: 10 MHz max.

Applications

- Position detection
- Image reading
- Encoders

Structure

Parameter	Specification	Unit
Number of pixels	4096	-
Pixel size	7×7	μm
Photosensitive area length	28.672	mm
Package	LCP (liquid crystal polymer)	-
Window material	Borosilicate glass (Tempax)	-

Absolute maximum ratings

Parameter	Symbol	Condition	Value	Unit
Supply voltage	Vdd	Ta=25 °C	-0.3 to +6	V
Clock pulse voltage	V(CLK)	Ta=25 °C	-0.3 to +6	V
Start pulse voltage	V(ST)	Ta=25 °C	-0.3 to +6	V
Operating temperature*1	Topr		-40 to +85	°C
Storage temperature*1	Tstg		-40 to +85	°C

Note: Exceeding the absolute maximum ratings even momentarily may cause a drop in product quality. Always be sure to use the product within the absolute maximum ratings.

*1: No condensation

Recommended terminal voltage (Ta=25 °C)

Parameter	Symbol	Min.	Typ.	Max.	Unit
Supply voltage	Vdd	4.75	5	5.25	V
Clock pulse voltage	High level	3	Vdd	Vdd + 0.25	V
	Low level	0	-	0.3	V
Start pulse voltage	High level	3	Vdd	Vdd + 0.25	V
	Low level	0	-	0.3	V

Input terminal capacitance (Ta=25 °C, Vdd=5 V)

Parameter	Symbol	Min.	Typ.	Max.	Unit
Clock pulse input terminal capacitance	C(CLK)	-	5	-	pF
Start pulse input terminal capacitance	C(ST)	-	5	-	pF

Electrical characteristics [Ta=25 °C, Vdd=5 V, V(CLK)=V(ST)=5 V]

Parameter	Symbol	Min.	Typ.	Max.	Unit
Clock pulse frequency	f(CLK)	200 k	5 M	10 M	Hz
Video data rate	VR	-	f(CLK)	-	Hz
Output impedance	Zo	70	-	260	Ω
Current consumption*2 *3	I	20	40	60	mA

*2: f(CLK)=10 MHz

*3: Current consumption increases as the clock pulse frequency increases. The current consumption is 10 mA typ. at f(CLK)=200 kHz.

Electrical and optical characteristics [Ta=25 °C, Vdd=5 V, V(CLK)=V(ST)=5 V, f(CLK)=10 MHz]

Parameter	Symbol	Min.	Typ.	Max.	Unit
Spectral response range	λ	400 to 1000			nm
Peak sensitivity wavelength	λ_p	-	600	-	nm
Photosensitivity*4	R	-	23	-	V/(lx·s)
Conversion efficiency*5	CE	-	25	-	$\mu\text{V}/e^-$
Dark output voltage*6	Vd	0	0.2	2	mV
Saturation output voltage*7	Vsat	1.5	2.0	2.5	V
Readout noise	Nr	0.5	1.0	1.8	mV rms
Dynamic range 1*8	DR1	-	2000	-	times
Dynamic range 2*9	DR2	-	10000	-	times
Output offset voltage	Vo	0.3	0.5	0.9	V
Photoresponse nonuniformity*4 *10	PRNU	-	±2	±10	%
Image lag*11	IL	-	-	0.1	%

*4: Measured with a tungsten lamp of 2856 K

*5: Output voltage generated per one electron

*6: Integration time=10 ms

*7: Difference from Vo

*8: DR1 = Vsat/Nr

*9: DR2 = Vsat/Vd

Integration time=10 ms

Dark output voltage is proportional to the integration time and so the shorter the integration time, the wider the dynamic range.

*10: Photoresponse nonuniformity (PRNU) is the output nonuniformity that occurs when the entire photosensitive area is uniformly illuminated by light which is 50% of the saturation exposure level. PRNU is measured using 4090 pixels excluding 3 pixels each at both ends, and is defined as follows:

$$\text{PRNU} = \Delta X/X \times 100 (\%)$$

X: average output of all pixels, ΔX : difference between X and maximum output or minimum output

*11: Signal components of the preceding line data that still remain even after the data is read out in a saturation output state.

Image lag increases when the output exceeds the saturation output voltage.

Spectral response (typical example)

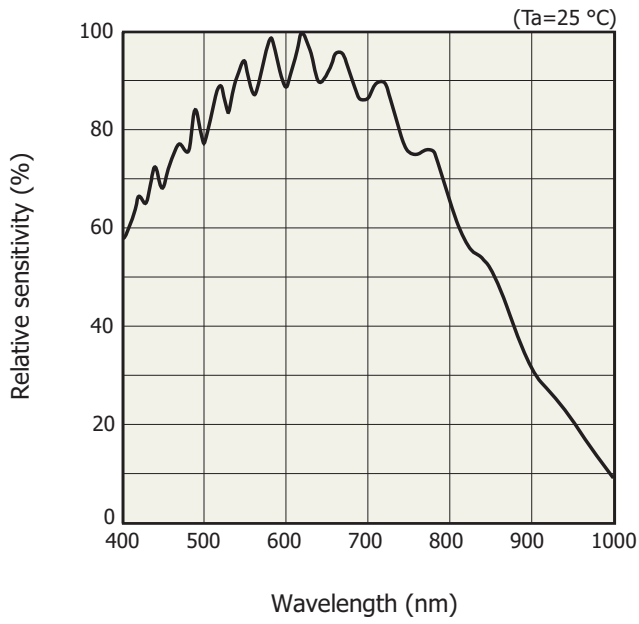

KMPDB0397EA

Block diagram

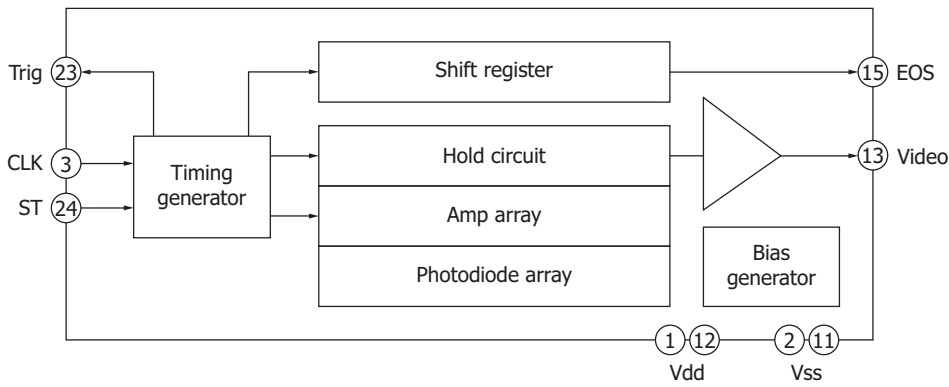

KMPDC0398EA

Output waveforms of one pixel

The timing for acquiring the Video signal is synchronized with the rising edge of Trig pulse (See red arrow below.).

$f(\text{CLK}) = \text{VR} = 10 \text{ MHz}$

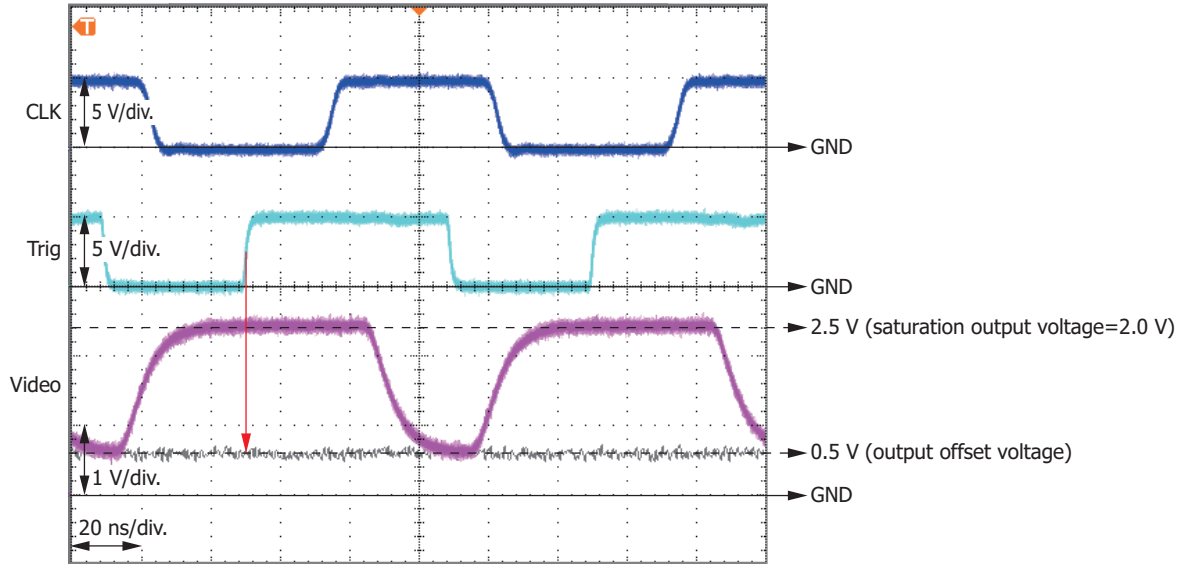

$f(\text{CLK}) = \text{VR} = 1 \text{ MHz}$

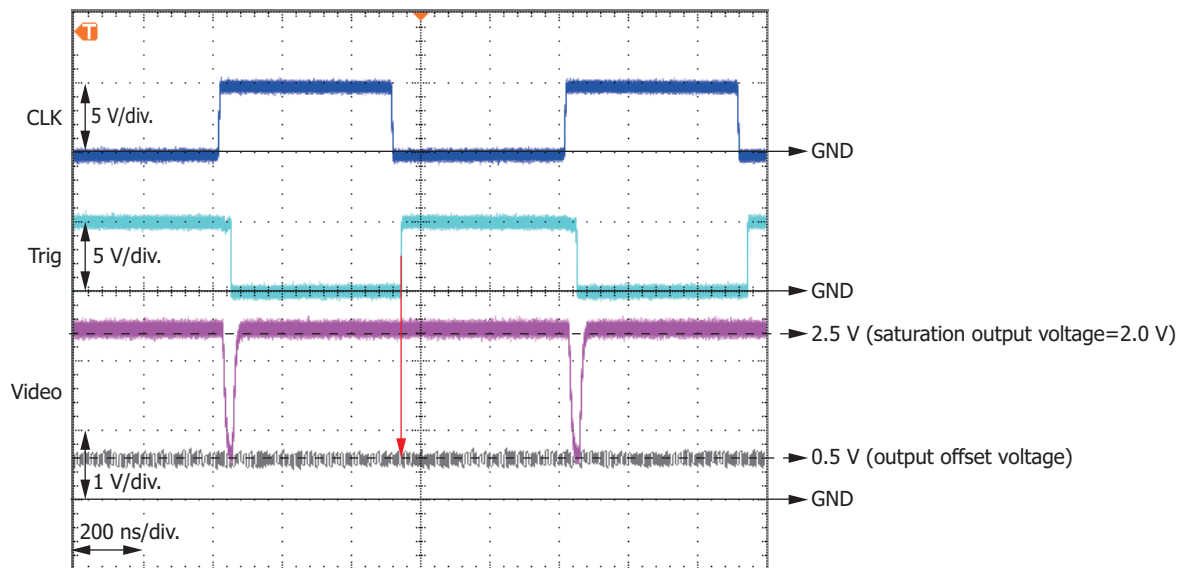

Timing chart

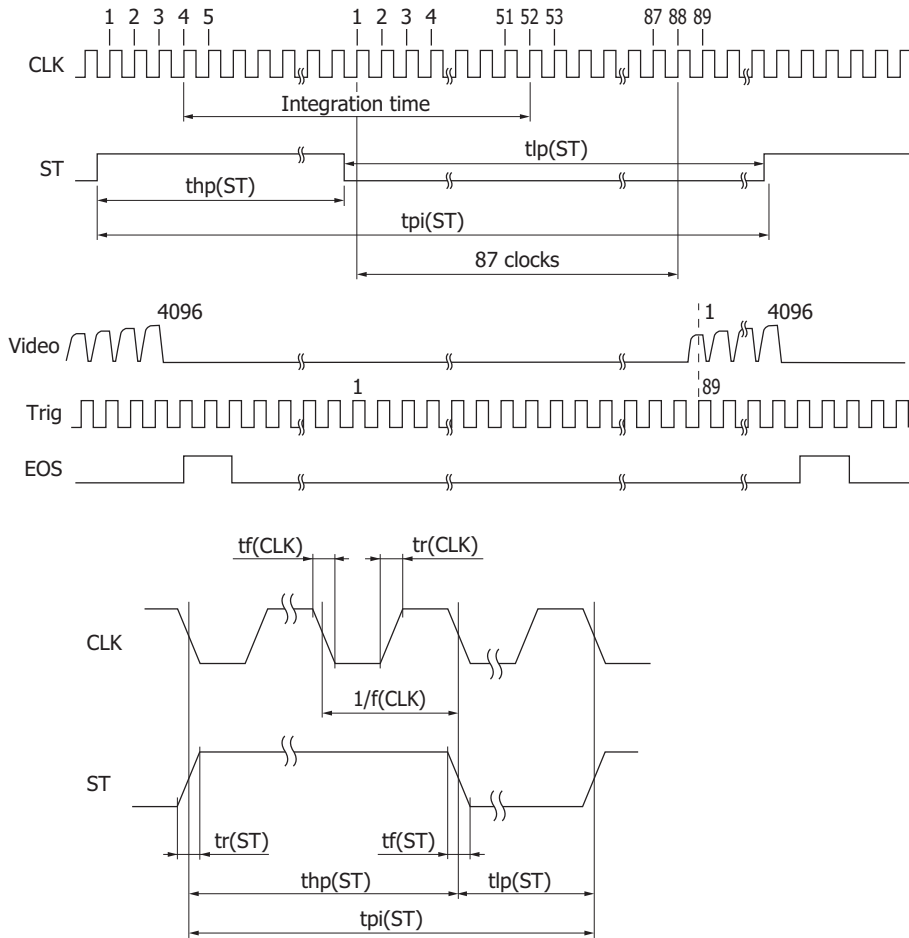

KMPDC0480EA

Parameter	Symbol	Min.	Typ.	Max.	Unit
Start pulse cycle*12	$t_{pi}(ST)$	$98/f(CLK)$	-	-	s
Start pulse high period*12 *13	$t_{hp}(ST)$	$6/f(CLK)$	-	-	s
Start pulse low period	$t_{lp}(ST)$	$92/f(CLK)$	-	-	s
Start pulse rise and fall times	$t_r(ST)$, $t_f(ST)$	0	10	30	ns
Clock pulse duty ratio	-	45	50	55	%
Clock pulse rise and fall times	$t_r(CLK)$, $t_f(CLK)$	0	10	30	ns

*12: Dark output increases if the start pulse cycle or the start pulse high period is lengthened.

*13: The integration time equals the high period of ST plus 48 CLK cycles.

The shift register starts operation at the rising edge of CLK immediately after ST goes low.

The integration time can be changed by changing the ratio of the high and low periods of ST.

If the first Trig pulse after ST goes low is counted as the first pulse, the Video signal is acquired at the rising edge of the 89th Trig pulse.

Operation example

This example assumes that the clock pulse frequency is maximized (video data rate is also maximized), the time of one scan is minimized, and the integration time is maximized

Clock pulse frequency = Video data rate = 10 MHz

Start pulse cycle = $4188/f(\text{CLK}) = 4188/10 \text{ MHz} = 418.8 \mu\text{s}$

High period of start pulse = Start pulse cycle - Start pulse's low period min.
 $= 4188/f(\text{CLK}) - 92/f(\text{CLK}) = 4188/10 \text{ MHz} - 92/10 \text{ MHz} = 409.6 \mu\text{s}$

Integration time is equal to the high period of start pulse + 48 cycles of clock pulses, so it will be $409.6 + 4.8 = 414.4 \mu\text{s}$.

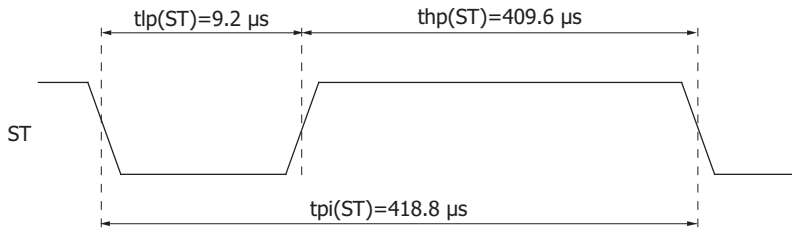

KMPDC0481EA

Dimensional outline (unit: mm)

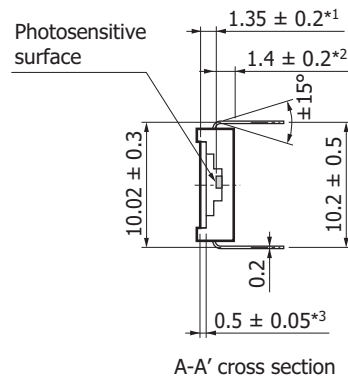
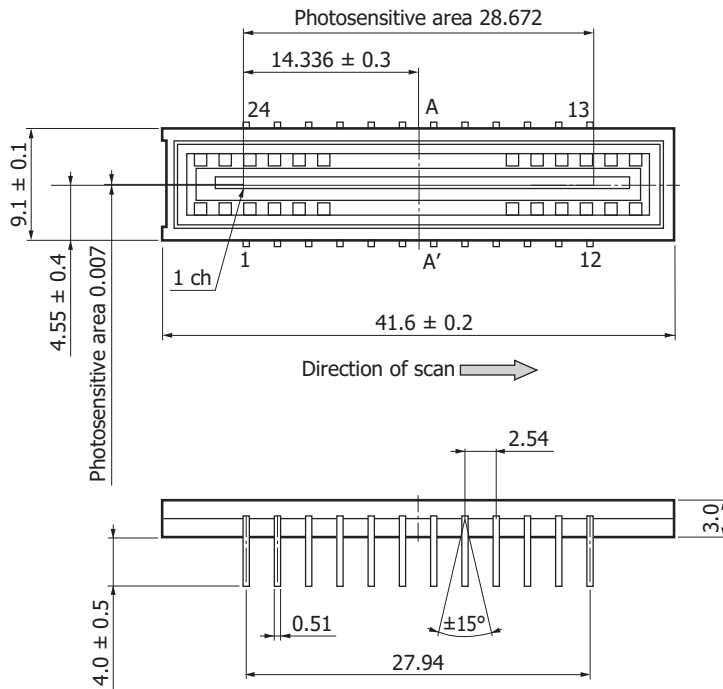

Tolerance unless otherwise noted: ± 0.1
 *1: Distance from window upper surface to photosensitive surface
 *2: Distance from package bottom to photosensitive surface
 *3: Glass thickness

KMPDA0309EA

Pin connections

Pin no.	Symbol	I/O	Description	Pin no.	Symbol	I/O	Description
1	Vdd	I	Supply voltage	13	Video	O	Video signal
2	Vss	-	GND	14	NC	-	No connection
3	CLK	I	Clock pulse	15	EOS	O	End of scan
4	NC	-	No connection	16	NC	-	No connection
5	NC	-	No connection	17	NC	-	No connection
6	NC	-	No connection	18	NC	-	No connection
7	NC	-	No connection	19	NC	-	No connection
8	NC	-	No connection	20	NC	-	No connection
9	NC	-	No connection	21	NC	-	No connection
10	NC	-	No connection	22	NC	-	No connection
11	Vss	-	GND	23	Trig	O	Trigger pulse for video signal acquisition
12	Vdd	I	Supply voltage	24	ST	I	Start pulse

Note: Leave the "NC" terminals open and do not connect them to GND.

Connect a buffer amplifier for impedance conversion to the video output terminal so as to minimize the current flow. As the buffer amplifier, use a high input impedance operational amplifier with JFET or CMOS input.

Application circuit example

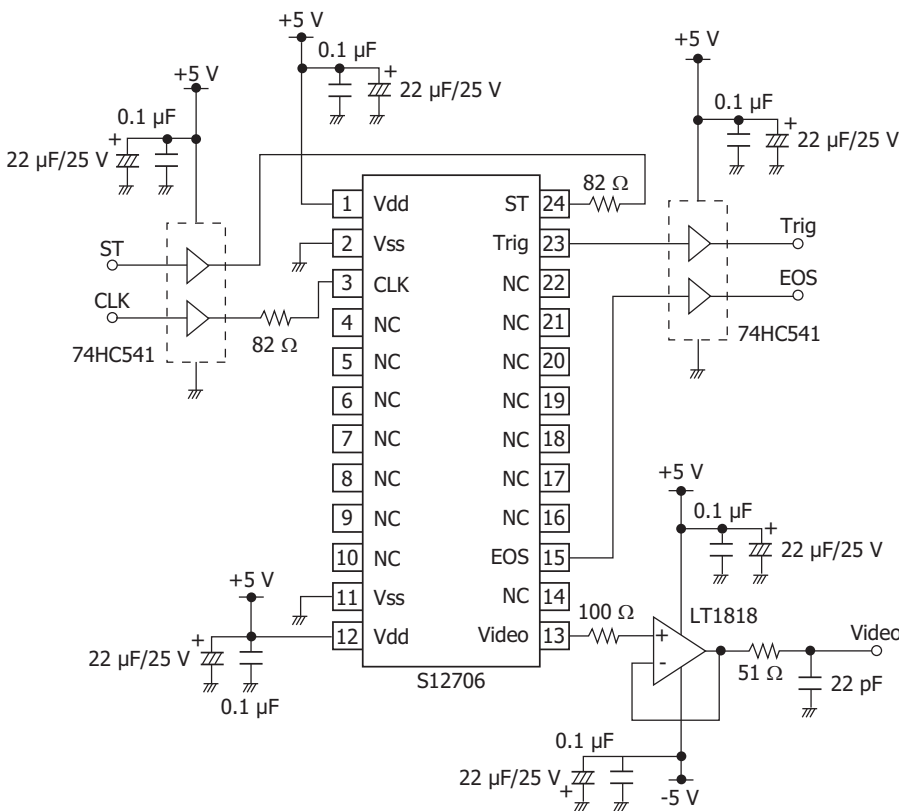

KMPDC0482EA

Precautions

(1) Electrostatic countermeasures

This device has a built-in protection circuit against static electrical charges. However, to prevent destroying the device with electrostatic charges, take countermeasures such as grounding yourself, the workbench and tools. Also protect this device from surge voltages which might be caused by peripheral equipment.

(2) Light input window

If dust or dirt gets on the light input window, it will show up as black blemishes on the image. When cleaning, avoid rubbing the window surface with dry cloth or dry cotton swab, since doing so may generate static electricity. Use soft cloth, paper or a cotton swab moistened with alcohol to wipe dust and dirt off the window surface. Then blow compressed air onto the window surface so that no spot or stain remains.

(3) Soldering

To prevent damaging the device during soldering, take precautions to prevent excessive soldering temperatures and times. Soldering should be performed within 5 seconds at a soldering temperature below 260 °C.

(4) Operating and storage environments

Always observe the rated temperature range when handling the device. Operating or storing the device at an excessively high temperature and humidity may cause variations in performance characteristics and must be avoided.

(5) UV light irradiation

This device is not designed to prevent deterioration of characteristics caused by UV exposure, so do not expose it to UV light.

Related information

www.hamamatsu.com/sp/ssd/doc_en.html

■ Precautions

- Notice
- Image sensor / Precautions

Information described in this material is current as of January, 2014.

Product specifications are subject to change without prior notice due to improvements or other reasons. This document has been carefully prepared and the information contained is believed to be accurate. In rare cases, however, there may be inaccuracies such as text errors. Before using these products, always contact us for the delivery specification sheet to check the latest specifications.

Type numbers of products listed in the delivery specification sheets or supplied as samples may have a suffix "(X)" which means preliminary specifications or a suffix "(Z)" which means developmental specifications.

The product warranty is valid for one year after delivery and is limited to product repair or replacement for defects discovered and reported to us within that one year period. However, even if within the warranty period we accept absolutely no liability for any loss caused by natural disasters or improper product use.

Copying or reprinting the contents described in this material in whole or in part is prohibited without our prior permission.

HAMAMATSU

www.hamamatsu.com

HAMAMATSU PHOTONICS K.K., Solid State Division

1126-1 Ichino-cho, Higashi-ku, Hamamatsu City, 435-8558 Japan, Telephone: (81) 53-434-3311, Fax: (81) 53-434-5184

U.S.A.: Hamamatsu Corporation: 360 Foothill Road, Bridgewater, N.J. 08807, U.S.A., Telephone: (1) 908-231-0960, Fax: (1) 908-231-1218

Germany: Hamamatsu Photonics Deutschland GmbH: Arzbergerstr. 10, D-82211 Herrsching am Ammersee, Germany, Telephone: (49) 8152-375-0, Fax: (49) 8152-265-8

France: Hamamatsu Photonics France S.A.R.L.: 19, Rue du Saule Trapu, Parc du Moulin de Massy, 91882 Massy Cedex, France, Telephone: 33-(1) 69 53 71 00, Fax: 33-(1) 69 53 71 10

United Kingdom: Hamamatsu Photonics UK Limited: 2 Howard Court, 10 Tewin Road, Welwyn Garden City, Hertfordshire AL7 1BW, United Kingdom, Telephone: (44) 1707-294888, Fax: (44) 1707-325777

North Europe: Hamamatsu Photonics Norden AB: Torshamnsgatan 35 16440 Kista, Sweden, Telephone: (46) 8-509-031-00, Fax: (46) 8-509-031-01

Italy: Hamamatsu Photonics Italia S.r.l.: Strada della Moia, 1 int. 6, 20020 Arese (Milano), Italy, Telephone: (39) 02-93581733, Fax: (39) 02-93581741

China: Hamamatsu Photonics (China) Co., Ltd.: B1201, Jiaming Center, No.27 Dongsanhuan Beilu, Chaoyang District, Beijing 100020, China, Telephone: (86) 10-6586-6006, Fax: (86) 10-6586-2866